

SolarVu[®] Installation Guide For Solis Three Phase Inverters

Introduction

SolarVu is an energy portal that enables remote monitoring of renewable energy generation sites over the internet. It requires the installation of a SolarVu gateway which continuously transfers data from the inverters to the remote SolarVu servers. This guide explains how to connect the M504 gateway to Solis Three Phase inverters. Several steps are required:

- 1) Connect the SolarVu gateway to the inverters
- 2) Connect the SolarVu gateway to the building LAN for internet access
- 3) Enter the communications settings into each inverter
- 4) Access SolarVu from a browser and configure the energy portal

Site Preparation

To access SolarVu from a browser, the inverters communicate serially with a SolarVu M504 gateway connected to the site network as shown in fig 1. The M504 connects to inverter(s) over RS485 using shielded twisted pair wire, daisy chained for multiple inverters. The LAN must have high speed internet service to an ISP to provide access to the internet. The M504 RJ45 ethernet jack plugs into an RJ45 LAN router or wall jack using a standard Cat5e patch cable of convenient length. Alternatively, SolarVu can be ordered with a 3G cellular modem for wireless internet connection. A 120VAC outlet for the gateway power dangle is required.

Fig 1 Typical connection for Acuvim II meter

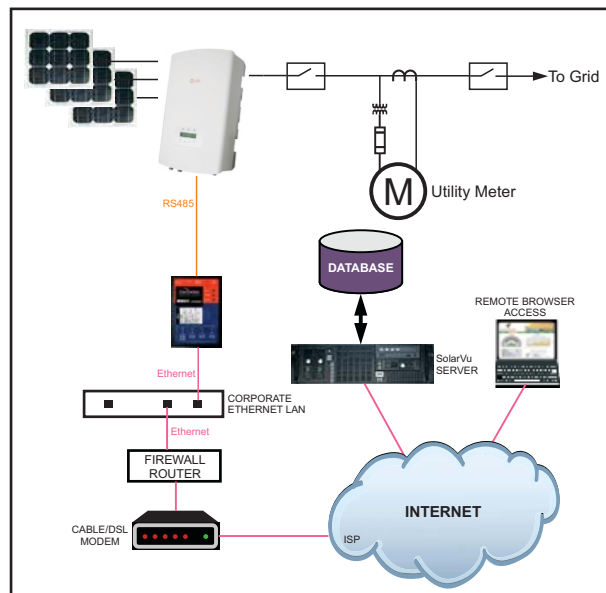

M504 Gateway Installation

Power Supply: Connect from a 120VAC source to the breaker (terminal L), terminal N and GND inside SolarVu enclosure as shown in fig 2.

RS485 Serial: Connect the RS485 serial Cat5e cable between the gateway terminals and the Solis inverter's RS485 terminal as shown in fig 3 and 4. Being careful to match the inverter type and correct wire colour to the terminals. Recommended cable type is Cat5e, 8 wire, UTP, #24 solid. Twisted pair must be used for the RS485 serial data wires. Use a tie wrap to provide strain relief for the Cat5e cable. Over 1000 feet of wire can be used for reliable serial communications.

Ethernet: Use a standard ethernet patch cable with RJ45 plug on each end of the appropriate length to connect from the RJ45 ethernet jack on the gateway to the network ethernet at a RJ45 wall jack or router/switch. This is usually an auto IP assignment using DHCP from a small sites but a larger commercial organization may require static IP settings specified by the IT system administrator. This should be specified at time of order. Settings as shipped can be verified from the SolarVu configuration sheet included in the enclosure document pouch. Alternatively, SolarVu can be ordered with a 3G cellular modem/router installed for wireless connection. This requires installation of a customer supplied SIM card with an active telco account for service.

Fig 2 Typical SolarVu enclosure

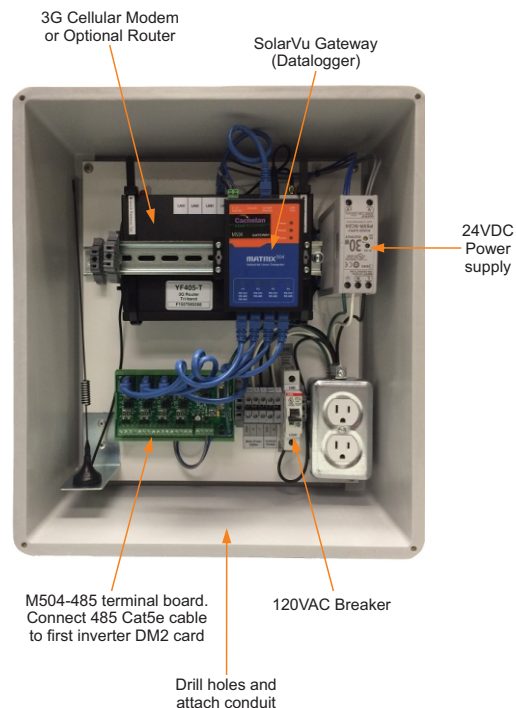

Inverter Communication Wiring

If the user is reading the electronic version of this guide, click the video link below for complete walk through for inverter communication wiring & configuration. If the user is reading the paper version, continue reading for the same content.



Solis Inverter Comm. Wiring and Configuration
<http://www.cachelan.com/link-solis>

Figure 3 shows the location of the RS485 terminals for inverter communication. Figure 4 shows the detailed wiring to connect from SolarVu M504 Comm. Module to the inverter(s). If there is only one inverter, connect the inverter's RS485 terminal A-IN and B-IN terminals (1 and 2) to the SolarVu M504-485 Terminal Board's D+ and D- contacts using a twisted pair. To connect more inverters, use another twisted pair to wire the A-OUT and B-OUT (3 and 4) terminals of the connected inverter together with the A-IN and B-IN (1 and 2) terminals of the inverter being added.

Fig 3 Solis inverter RS485 terminal layout

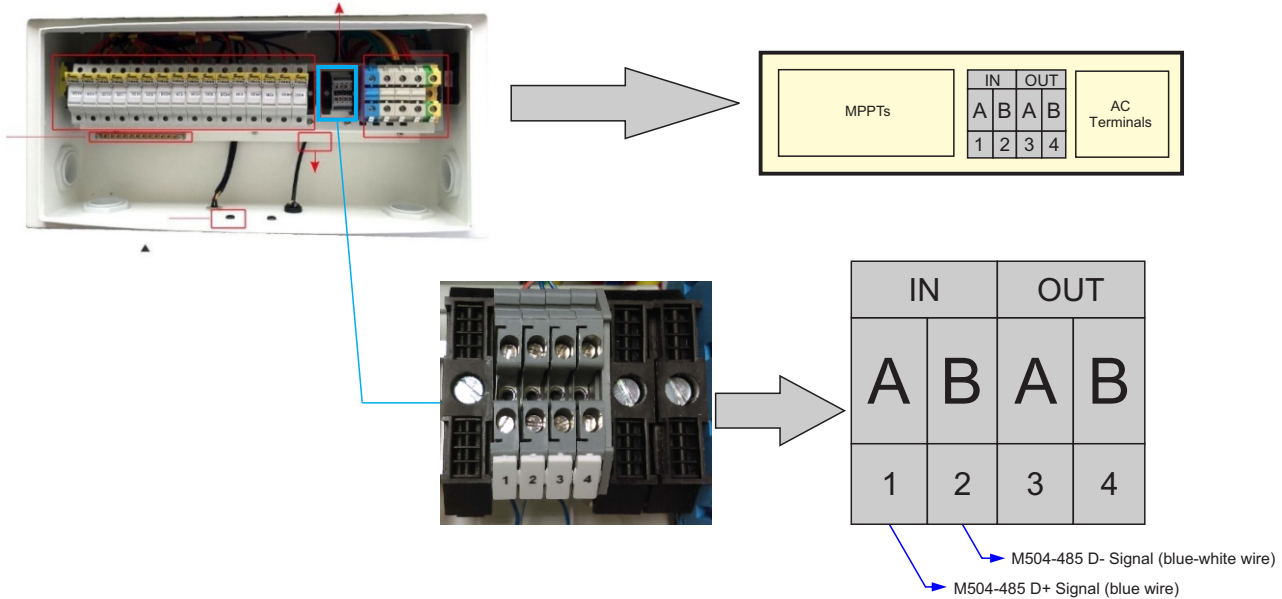
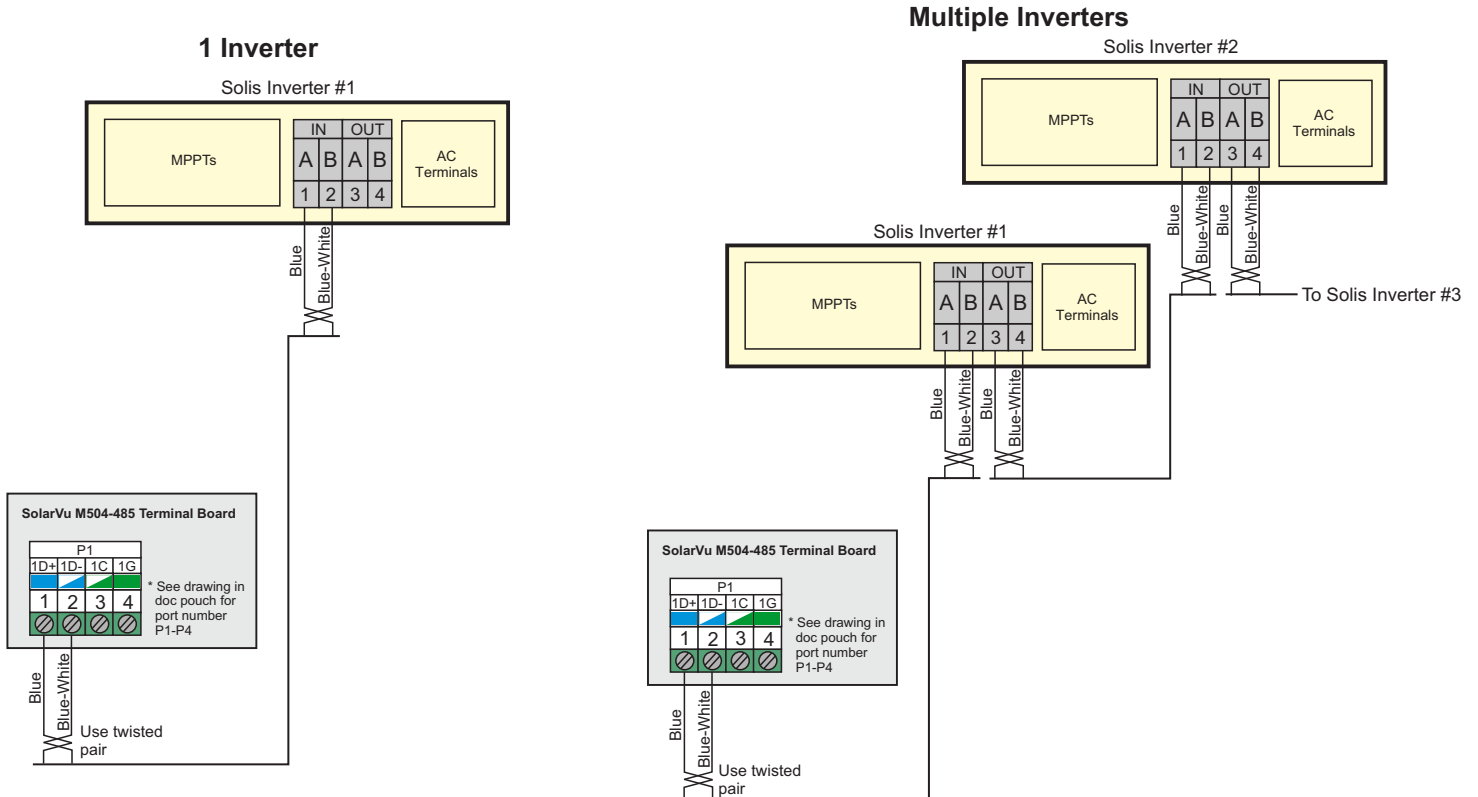

Fig 4 Wiring one or several Solis Inverters



Inverter Configuration

Each Solis inverter must be configured with a unique Slave Address, which is also referred to as its ModBus address or ID. Required inverter number settings are found in the SolarVu enclosure document pouch on the door and are normally assigned as 1,2,3... to match the inverter number. Each Solis inverter must be powered on with a DC input to access the front panel display for entering settings. Follow the following sequence for entering the settings for each inverter individually. It may be necessary to power cycle (off then on) the inverter after making changes to ensure the inverter is using the newly assigned address ID. The baud rate for this inverter is fixed at 9600 with 1 stop bit and no parity. These settings cannot be changed by the user.

Fig 5 Configuring Inverter Address

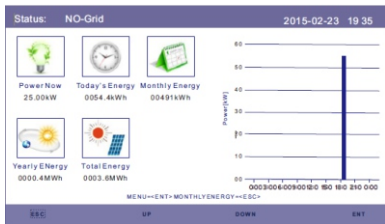

On the initial interface, press the 'ENTER' key to view the menu.

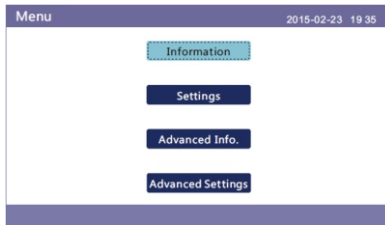

Once the main menu is open, use the 'DOWN' key to select the 'Settings' tab, then press the 'ENTER' key to open the sub-menu.



Within the 'Settings' sub-menu, use the 'DOWN' key to select the 'Set Address' tab, then press the 'ENTER' key to open the 'Set Address' screen.



Refer to Cachelan communication SLD for detailed inverter address assignment. Typically configure inverter address to match the inverter number, i.e. inverter #1 has address 1, inverter #2 has address 2 and etc...

To enter the address, use the 'UP' and 'DOWN' keys to get to the required address, then press the 'ENTER' key to submit the change.

Network Setup

On power up, the gateway looks for a DHCP server to provide it a dynamic IP address. If a PC connected to the network can automatically connect to the internet through a browser then the network is already configured to accept the gateway. If a dedicated IP address was programmed instead, subnet mask and DNS server address are required. This needs to be entered into the gateway before shipment. Network configuration is shown on the gateway label and the Configuration Settings page in the doc pouch. Once the gateway receives its IP address it acts as a client. It will automatically try to connect to the SolarVu server and begin transferring data from the inverter to the server.

Fig 6 M504 Gateway Indicators

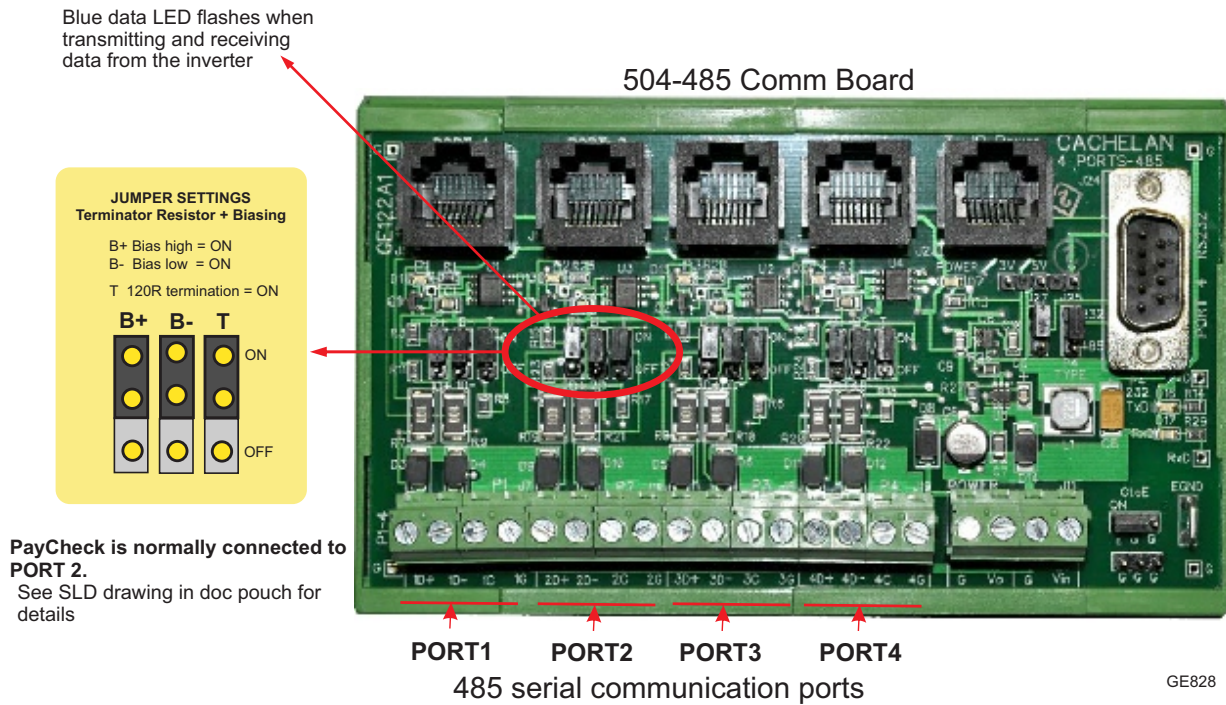

INDICATOR STATUS		
LED	NORMAL	STATUS
Power	●	OFF-no power ON-power OK
Ready	●	ON M504 booted up and running
Link/Act	●	OFF-no ethernet connection FLASH- data traffic activity
P1	●	Serial Port 1 usually inverter Transmit=orange, Receive=green, flashing
P2	●	Serial Port 2 usually option Transmit=orange, Receive=green, flashing
P3	●	Serial Port 3 usually option Transmit=orange, Receive=green, flashing
P4	●	Serial Port 4 usually option Transmit=orange, Receive=green, flashing

TROUBLESHOOTING CHECKLIST	
IP Address	Obtain IP by DHCP or set static IP Network must be configured to same settings
Serial	Check inverter connected to correct port. Polarity of serial twisted pair wires. Serial ID entered correctly in each inverter
Inverter	Powered on. Serial ID has been set to match SLD drawing. Serial wiring correct.
Internet	Internet connection for ISP to LAN working
Support	For Cachelan technical support 905.470.8400 x224 contactus@cachelan.com

GE829

Testing the System

At this point the installation should be complete ready for testing. It is helpful to have access to a PC that is connected to the internet for viewing SolarVu screens. Using the URL supplied for the system. The gateway is preconfigured to automatically send inverter data to the SolarVu servers. To do this it must first establish an internet connection. Then it will collect data from the inverters and periodically transmit it. Verifying correct operation is described in the sections that follow. Indicator lights and actual values accessible from the SolarVu Analyzer > Inverter Status screen figure 6 are useful for determining the status of the system.

Fig 6 Use the ANALYZER > Inverter Status screen to check system status

To access the inverter status screen, enter the SolarVu URL in your browser. Click ANALYZER

Solis Inverter #1 (Device ID : 1)

DC Input	Power 1	552 W	Voltage 1	607 V	Current 1	0.9 A
	Power 2	228 W	Voltage 2	617 V	Current 2	0.4 A
AC Output	Power	547 W	Voltage	281 V	Current	2.7 A
	Efficiency	70%	Frequency	60.0 Hz		
Phase	Current A	0.9 A	Current B	0.8 A	Current C	1.0 A
	Voltage A-B	281 V	Voltage B-C	283 V	Voltage C-A	284 V
Inverter	Solis 25k-US				Comm	DM2 Modbus
Status	Normal operation					
Fault	None					

Time of last update received from SolarVu gateway: Monday, November 28, 2016 4:08:33 PM (GMT -5:00)

Last Data Updated: Nov 28, 2016, Mon 4:05 PM (GMT -5:00)

Last Communication: Nov 28, 2016, Mon 4:07 PM (GMT -5:00)

Measured values from the inverter

Time of last update received from SolarVu gateway

Status reported by inverter
Faults reported by inverter

Light is green if K135 is reading valid data from the inverter over RS485. SolarVu gateway must be connected to the internet

Light goes green if SolarVu gateway to the internet

Support

See the What is SolarVu? video at www.solarvu.net for a feature overview. Each screen has a HELP button with details for the items on that view. A printable HELP guide can be downloaded in SETUP > DOWNLOAD.

For additional technical support, send an email to contactus@cachelan.com or dial our support line in Toronto, Canada at 905.470.8400

Cachelan Technical Support
contactus@cachelan.com
905.470.8400 x224